

36005 Series V-Max[®]

High Capacity V-Ported
Control Ball Valve



Caution: The instructions on the following pages should be thoroughly reviewed and understood prior to installing, operating, or performing maintenance on this equipment. Throughout the text, safety and/or caution notes will appear and must be strictly adhered to; otherwise, serious injury or equipment malfunction could result.

Table of Contents	Page
1.0 INTRODUCTION	
PARTS	2
SERVICE	2
TRAINING	2
2.0 INSTALLATION	
2.1 GENERAL	4
2.2 PIPELINE MOUNTING.....	4
2.3 AIR PIPING	4
2.4 CHANGING ACTUATOR POSITION.....	4
2.5 CHANGING VALVE ACTION.....	6
3.0 MAINTENANCE	
3.1 BRACKET SUBASSEMBLY	7
3.3 BODY SUBASSEMBLY	9
3.3.1 PACKING.....	9
3.3.2 MN-7 SEAL RING	9
3.3.3 STANDARD METAL SEAL RING	9
3.3.4 HEAVY DUTY METAL SEAL RING	9
3.3.5 BALL PLUG	10
3.4 ACTUATOR SUBASSEMBLY	11
3.5 HANDWHEEL SUBASSEMBLY	12
3.6 DIAPHRAGM REPLACEMENT	13
 LIST OF FIGURES	
FIGURE 1 — NUMBERING SYSTEM AND STANDARD MOUNTING POSITIONS	2
FIGURE 2 — GENERAL ASSEMBLY	15
FIGURE 3 — ACTUATOR SIZES B & C BRACKET & LINKAGE	16
FIGURE 4 — HANDWHEEL ASSEMBLY, ACTUATOR SIZES B & C	16
FIGURE 5 — HANDWHEEL DETAIL, ACTUATOR SIZES B & C	16
FIGURE 6 — HANDWHEEL BRACKET DETAIL, SIZES B & C	16
FIGURE 7 — HANDWHEEL LEVER DETAIL, SIZES B & C	16
FIGURE 8 — HANDWHEEL CLEVIS DETAIL, SIZES B & C	16
FIGURE 9 — ACTUATOR GENERAL ASSEMBLY, SIZES B & C	17
FIGURE 10 — LEVER POSITION AIR TO OPEN, SIZES B & C	17
FIGURE 11 — LEVER POSITION AIR TO CLOSE, SIZES B & C	17
FIGURE 12 — POSITION INDICATOR DETAIL, SIZES B & C	18
FIGURE 13 — SIZE AC ACTUATOR ASSEMBLY	18
FIGURE 14 — SIZE AC ACTUATOR BOTTOM VIEW	19
FIGURE 15 — SIZE AC ACTUATOR LINKAGE DETAIL	19
FIGURE 16 — SIZE AC HANDWHEEL DETAIL	20
FIGURE 17 — INSULATION DETAIL	20
 LIST OF TABLES	
TABLE 1 — BODY PARTS LIST	21
TABLE 2 — BRACKET AND LINKAGE PARTS LIST	21
TABLE 3 — HANDWHEEL PARTS LIST	22
TABLE 4 — ACTUATOR PARTS LIST	22
TABLE 5 — LINE BOLTING	23

Helpful Hints

1. Have spare parts on hand before starting.
2. Read the instructions carefully.
3. Study the figures carefully and identify each part.
4. Use the right tools for the job.
5. Be careful not to score the shaft, ball and guiding surfaces.
6. Insure all lubricants, gaskets and packing are compatible with the service.
7. Don't overtighten nuts or bolts.
8. Clean valve parts thoroughly before reassembly.
9. Work safely.

Copyright

Masoneilan® is a registered trademark of Dresser, Inc. All information contained herein is believed to be accurate at the time of publication and is subject to change without notice.

Copyright 2007 by Dresser, Inc. All rights reserved.

Safety Information

Important - Please Read Before Installation

Masoneilan 36005 Series instructions contain **DANGER**, **WARNING**, and **CAUTION** labels, where necessary, to alert you to safety related or other important information. Read the instructions carefully **before** installing and maintaining your control valve. **DANGER** and **WARNING** hazards are related to personal injury. **CAUTION** hazards involve equipment or property damage. Operation of damaged equipment can, under certain operational conditions, result in degraded process system performance that can lead to injury or death. Total compliance with all **DANGER**, **WARNING**, and **CAUTION** notices is required for safe operation.



This is the safety alert symbol. It alerts you to potential personal injury hazards. Obey all safety messages that follow this symbol to avoid possible injury or death.



Indicates a potentially hazardous situation which, if not avoided, could result in death or serious injury.



Indicates a potentially hazardous situation which, if not avoided, could result in serious injury.



Indicates a potentially hazardous situation which, if not avoided, could result in minor or moderate injury.



When used without the safety alert symbol indicates a potentially hazardous situation which, if not avoided, could result in property damage.

Note: Indicates important facts and conditions.

About this Manual

- The information in this manual is subject to change without prior notice.
- The information contained in this manual, in whole or part, shall not be transcribed or copied without Masoneilan's written permission.
- Please report any errors or questions about the information in this manual to your local supplier.
- These instructions are written specifically for the 36005 Series control valves, and do not apply for other valves outside of this product line.

Warranty

Items sold by Dresser® are warranted to be free from defects in materials and workmanship for a period of one year from the date of shipment provided said items are used according to Dresser recommended usages. Dresser, Inc. reserves the right to discontinue manufacture of any product or change product materials, design or specifications without notice.

This instruction manual applies to the Masoneilan 36005 Series control valves.

The Control Valve MUST BE:

- Installed, put into service and maintained by qualified and competent professionals who have undergone suitable training.
- Under certain operating conditions, the use of damaged equipment could cause a degradation of the performance of the system which may lead to personal injury or death.
- Changes to specifications, structure, and components used may not lead to the revision of this manual unless such changes affect the function and performance of the product.
- All surrounding pipe lines must be thoroughly flushed to ensure all entrained debris has been removed from the system.

1.0 Introduction

The following instructions are designed to assist maintenance personnel in performing most of the maintenance required on the 36005 V-Max® valve and if followed carefully will reduce maintenance time.

Masoneilan has highly skilled Service Engineers available for start-up, maintenance and repair of our valves and component parts. In addition, regularly scheduled training programs are conducted to train customer service and instrumentation

personnel in the operation, maintenance and application of our control valves and instruments. Arrangements for these services can be made through your Masoneilan Representative or District Office. When performing maintenance use only Masoneilan replacement parts. Parts are obtainable through your local Masoneilan Representative or District Office. When ordering parts always include **MODEL** and **SERIAL NUMBER** of the unit being repaired.

Numbering System

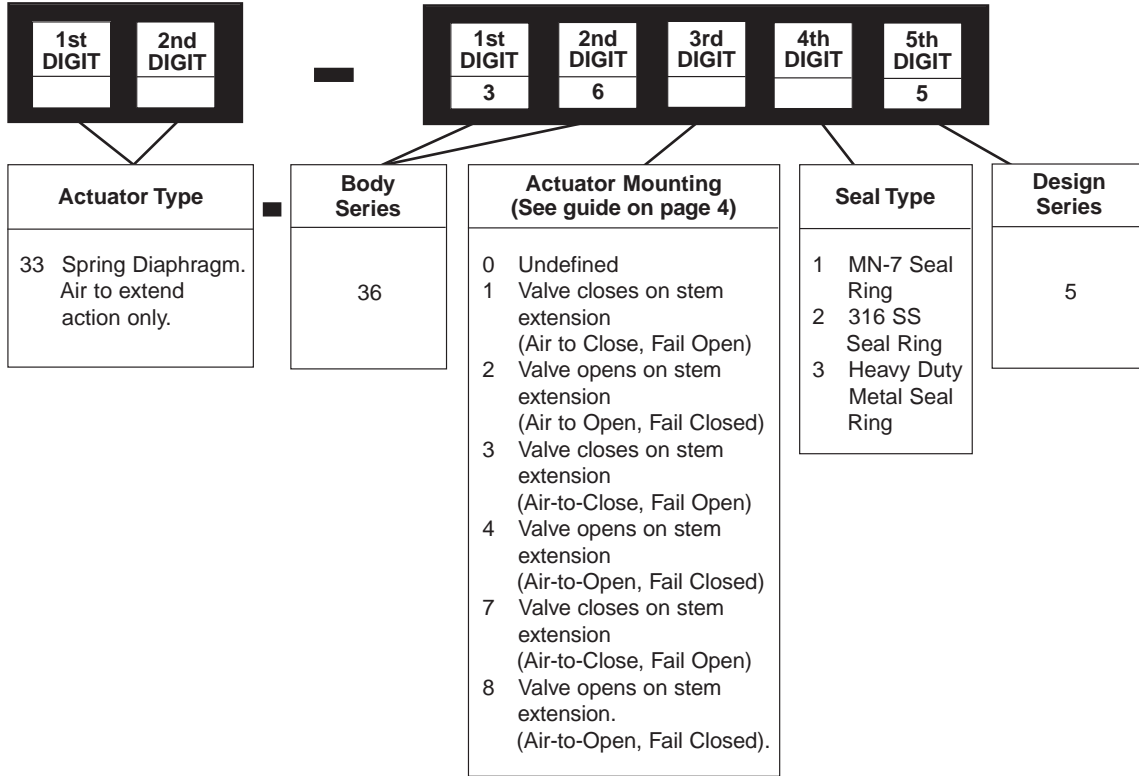

Figure 1

V-Max Valves

3 X - 3 6 X 0 5

Actuator Position in Relation to Valve Body
Numbering System: 1 to 8

Actuator Model 33, Size AC

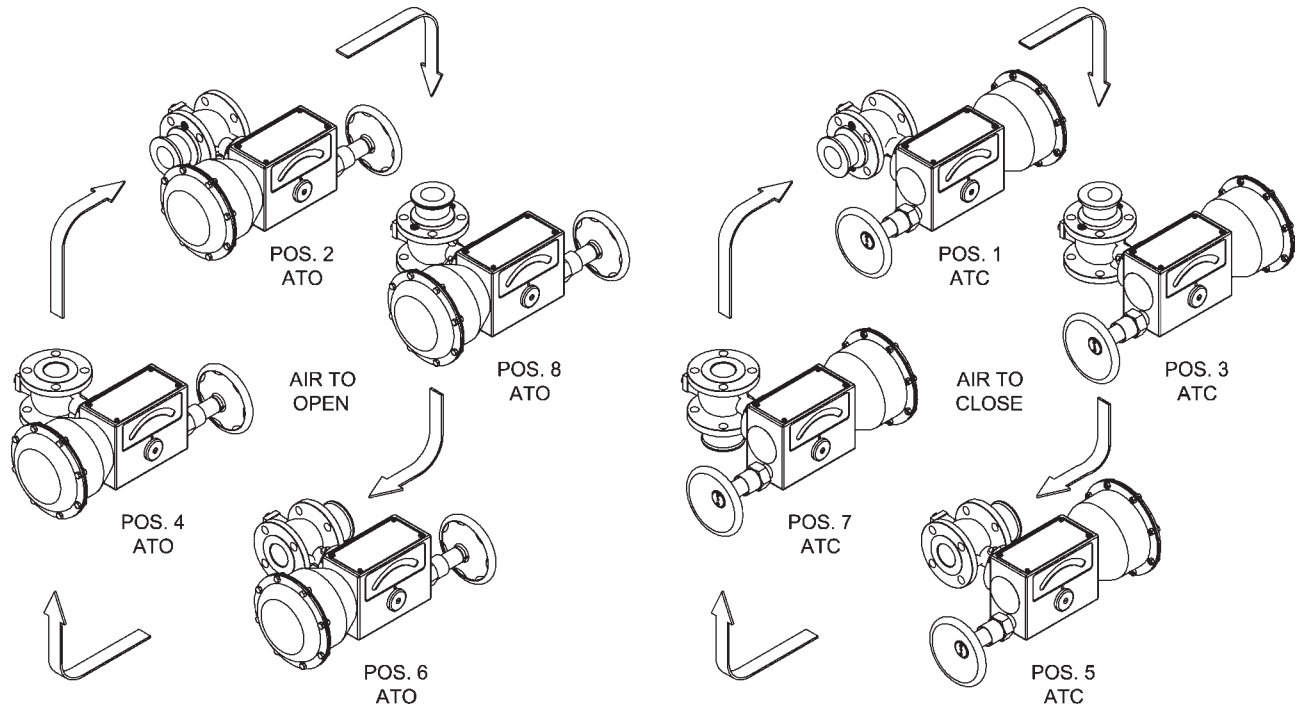

Actuator Model 33, Sizes B and C

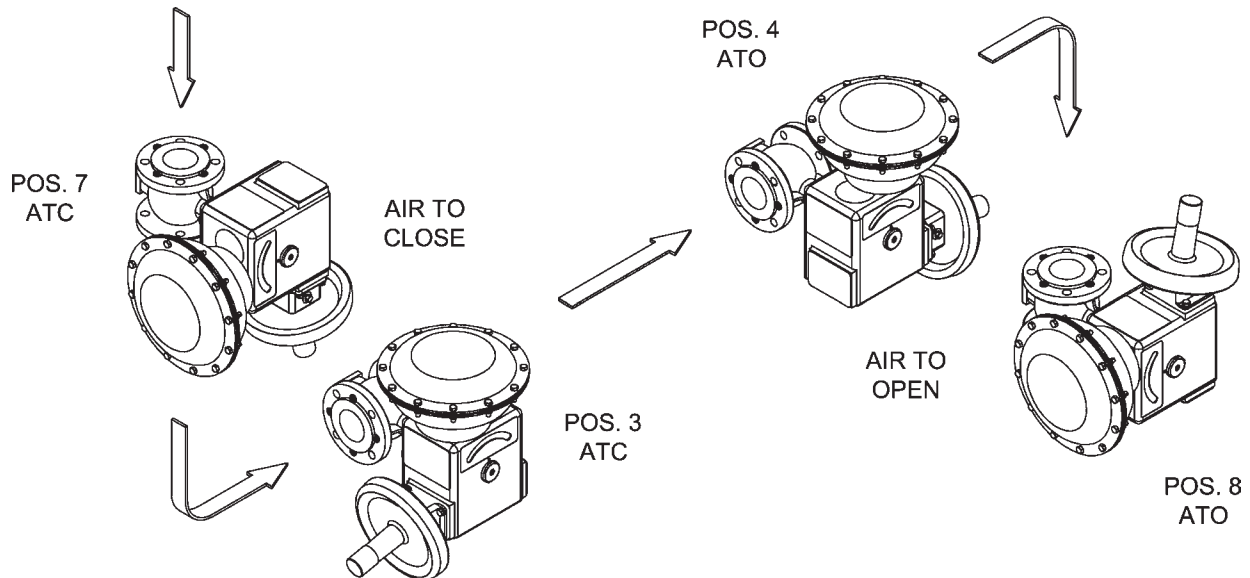

Installation

2.1 General

2.1.1 Unpack valve carefully to avoid damage to valve, accessories, or tubing.

2.1.2 Record all valve and accessory serial plate data for future reference. Always provide serial and model numbers when ordering spare parts.

2.2 Pipeline Mounting

CAUTION

Do not remove button head screw (9) and washer (10) during installation. The function of these parts is to hold the retainer (3) and seal ring (8) in place and should be removed only when the valve is to be disassembled for maintenance (Figure 2).

- A. Before installing the valve in the line, clean pipe and valve of all foreign materials such as welding chips, scale, oil, grease or dirt. Gasket surfaces must be thoroughly cleaned to ensure leak free joints.
- B. Install valve in a horizontal or vertical line with the flow tending to push the seal ring (8) against the ball (2) as indicated by the flow arrow cast into the body. It is recommended that if adjacent walls and piping permit, the valve be oriented such that the ball opens upward. This is especially important when handling slurries. See Figure 1 for actuator mounting positions and for flow direction and Table 5 for line flange bolting lengths.

Note: Flange bolt lengths are non-standard on inlet and standard on outlet side.

- C. Tighten bolting evenly and in crisscross fashion so that the retainer (3) held in place by the line flange will bear evenly against the seal ring (8).
- D. The linkage of the 36005 V-Max valve has been properly adjusted at the factory and requires no further adjustment.
- E. Where insulation of the valve body is required, do not insulate the valve bonnet. See Figure 17.

2.3 Air Piping

2.3.1 Air piping must be adequately sized to provide the regulated supply pressure specified on the nameplate. As a general guideline, use 1/4" O.D. tubing or equivalent for all air lines. If supply air line exceeds 25 feet in length, use 3/8" O.D. tubing.

2.3.2 The actuator is furnished with a 1/4" NPT instrument air port on the upper case.

CAUTION

Do not exceed loading pressure specified on the valve nameplate.

2.4 Changing Actuator Position

2.4.1 Model 33, sizes B & C. For Size AC, refer to section 2.4.2.

CAUTION

Before proceeding with changing actuator position, air action or valve maintenance, isolate valve, vent process pressure and shut off air supply and signal air lines or electrical lines to unit. It is recommended that the valve be removed from the pipeline prior to maintenance work. Keep hands and tools away from the segmental ball, particularly when disconnecting the actuator stem from shaft arm as ball may rotate freely to its lowest position

For each valve action (air to open/air to close) the actuator may be positioned to either side of the pipe. Actuator position is usually determined by adjacent piping, obstacles of various types or air piping arrangements. To reposition the actuator and/or bracket follow the disassembly and reassembly instructions below.

Note: Actuator positioning should be performed prior to installing the valve in the pipeline. To change actuator position and/or valve action refer to Figure 1 for desired position.

- A. Remove valve from process line after closing isolating valves and disconnecting all pneumatic tubing and electrical wiring.
 - B. If valve is equipped with a handwheel (Figure 4) disengage handwheel and remove retaining clips (63), clevis pin (66) and pivot pins (72); remove entire handwheel assembly from bracket (62).
 - C. Remove pivot pin retaining clips (40), pivot pin (39) and spacer rings (69). Remove actuator hex nuts (75) and washers (76). Remove actuator.
- Note: Spacer rings apply only on handwheel option.**
- D. Remove shaft cover (42) and screw (43). Loosen lever cap screw (33). Remove packing flange stud nuts (24), bracket mounting stud nuts (24) and washers (18). Loosen ball plug indicator arm (35).
 - E. If necessary, scribe a witness line on the lever (32) in relation to the slot on the end of the shaft (5).
- Note: Standard lever has arrows stamped into it for alignment. For handwheel lever use slot for alignment.**
- F. Slide bracket (31) away from body until it clears bracket and packing flange studs (26 and 25), allowing lever (32) lever arm (64) and indicator arm (35) to be removed from shaft. Total removal of the bracket is not required.

CAUTION

Before proceeding determine valve action (air to open/air to close), refer to the appropriate figure (Figure 10 to open, Figure 11 to close). To obtain proper alignment, the lever must be oriented on the shaft so that the slot in the end of the shaft and arrows or indicator lines are aligned as shown; with the ball in the closed position, the distance between the top of the bracket and the top of the pivot pin must be as shown.

- G. Slide lever (32) and lever arm (64) back onto shaft in desired position. Slide indicator arm (35) back onto shaft. Align bracket and slide back onto bracket mounting studs (26) and packing flange studs (25). Replace bracket mounting stud nuts (24) and washers (18). Slide packing flange (23) back onto packing flange studs (25) and replace packing flange stud nuts (24).
- H. Remount actuator onto bracket and replace actuator mounting hex nuts (75) and washers (76). Position lever (32) and lever arm (64) so that rod end bearing (94) lines up in lever (32). Tighten lever cap screws (34).
- I. Rotate ball plug (2) to closed position. If actuator action is air to open loosen rod end bearing locknut (93) and adjust position of rod end bearing (94) so that holes in lever (32) and rod end bearing (94) line up. Insert pivot pin (39) and replace spacer rings (69) and retaining rings (40).

CAUTION

When stroking valve keep hands and equipment clear of ball plug and seal ring to avoid injury or damage to personnel and equipment.

- J. If action is air to close place ball plug (2) in closed position and pneumatically stroke actuator fully.

CAUTION

Do not exceed maximum air supply pressure. Keep hands clear of actuator stem and linkage.

Loosen rod end bearing locknut (93) and adjust rod end bearing (94) so that holes in lever (32) and rod end bearing (94) line up. Insert pivot pin (39) and spacers (69) and replace retaining rings (40).

- K. For both air to open and air to close action, stroke valve fully to ensure proper closure of ball plug and operation of valve. It may be necessary to readjust rod end bearing slightly by loosening locknut and rotating stem.
- L. Replace handwheel assembly in bracket (62), pivot pins (72) and retaining clips (63).
- M. Replace shaft cover (42) and screw (43).
- N. Set and lock indicator arm (35) to indicate plug position.

2.4.2 Changing Actuator Position Model 33, size AC only.

CAUTION

Before proceeding with changing actuator position, air action or valve maintenance, isolate valve, vent process pressure and shut off air supply and signal air lines or electrical lines to unit. It is recommended that the valve be removed from the pipeline prior to maintenance work. Keep hands and tools away from the segmental ball, particularly when disconnecting the actuator stem from shaft arm as ball may rotate freely to its lowest position.

For each valve action (air to open/air to close) the actuator may be positioned to either side of the pipe. Actuator position is usually determined by adjacent piping, obstacles of various types or air piping arrangements. To reposition the actuator and/or bracket follow the disassembly and reassembly instructions below.

Note: Actuator positioning should be performed prior to installing the valve in the pipeline. To change actuator position and/or valve action refer to Figure 1 for desired position.

- A. Remove valve from process line after closing isolating valves and disconnecting all pneumatic tubing and electrical wiring.
- B. If valve is equipped with a handwheel (Figures 13 & 16) disengage handwheel and remove retaining clip (54-7) and washer (54-4). Remove entire handwheel assembly from actuator housing (31).
- C. Remove pivot pin retaining clips (40), pivot pin (39). Remove actuator hex nuts (75) and washers (76). Remove actuator.
- D. Remove shaft cover (42) and screw (43). Loosen lever cap screw (33). Remove packing flange stud nuts (24), bracket mounting stud nuts (24) and washers (18). Loosen ball plug indicator arm (35).
- E. If necessary, scribe a witness line on the lever (32) in relation to the slot on the end of the shaft (5).
- F. Slide housing (31) away from body until it clears bracket and packing flange studs (26 and 25), allowing lever (32) and indicator arm (35) to be removed from shaft. Total removal of the bracket is not required.

CAUTION

Before proceeding determine valve action (air to open/air to close).

- G. Slide lever (32) back onto shaft in desired position. Slide indicator arm (35) back onto shaft. Align bracket and slide back onto mounting studs (26) and packing flange studs (25). Replace mounting stud nuts (24) and washers (18). Slide packing flange (23) back onto packing flange studs (25) and replace packing flange stud nuts (24).
- H. Remount actuator onto housing and replace actuator mounting hex nuts (75) and washers (76). Position lever (32) so that rod end bearing (94) lines up in lever (32) and that the pads on the lever will contact the stop bolts (102). Tighten lever cap screw (33).
- I. Rotate ball plug (2) to closed position. Adjust closed position travel stop (102) until it contacts the pad on lever (32). Tighten locknut (101).
- J. Rotate ball plug (2) to open position. Adjust open position travel stop until it contacts pad on lever (32). Tighten locknut (101).

CAUTION

Ensure rotation of AC actuator does not exceed 90deg. Damage to actuator rod may result.

- K. If actuator action is air to open, rotate ball plug (2) to open position. Pneumatically stroke actuator to open position. Loosen rod end bearing locknut (93) and adjust position of rod end bearing (94) so that holes in lever (32) and rod end bearing (94) line up. Insert pivot pin (39) and retaining rings (40).

CAUTION

When stroking valve keep hands and equipment clear of ball plug and seal ring to avoid injury or damage to personnel and equipment.

- L. If action is air to close place ball plug (2) in closed position. The pad on lever should contact the closed position travel stop (102). If it does not, repeat adjustment as noted in step I above. Return ball plug (2) to open position. Pneumatically stroke actuator to open position.

CAUTION

Do not exceed maximum air supply pressure. Keep hands clear of actuator stem and linkage.

- Loosen rod end bearing locknut (93) and adjust rod end bearing (94) so that holes in lever (32) and rod end bearing (94) line up. Insert pivot pin (39) and replace retaining rings (40).
- M. For both air to open and air to close action, stroke valve fully to ensure proper closure of ball plug and operation of valve. It may be necessary to readjust rod end bearing slightly by loosening locknut and rotating stem.
- N. Replace handwheel assembly in housing (31), washer (54-7) and retaining clip (54-4).
- O. Replace shaft cover (42) and screw (43).
- P. Set and lock indicator arm (35) to indicate plug position.

2.5 Changing Valve Action

Note: If the valve action is to be changed it should be done before the valve is installed in the line. This allows a positive visual check to ensure that the ball plug is fully closed when the actuator is in the proper position.

2.5.1 Model 33, sizes B & C only. For size AC refer to section 2.5.2

- A. If the valve is equipped with a handwheel disengage the handwheel and remove retaining clips (63), clevis pin (66), and pivot pins (39). Remove cap screws (70), washers (71) and handwheel bracket (62).
- B. If necessary, scribe a witness mark on the lever (32) in relation to the slot on the end of the shaft (5).

Note: Standard lever has arrows stamped into it for alignment. For handwheel lever use slot for alignment.

- C. Remove pivot pin retaining clips (40), pivot pin (39) and spacer rings (69). Remove shaft cover (42) and screw (43). Remove actuator hex nuts (75) and washers (76). Remove actuator.

Note: Spacer rings apply only on handwheel option.

- D. Loosen lever cap screw (33). Remove packing flange stud nuts (24), bracket mounting stud nuts (24) and washers (18). Loosen ball plug indicator arm (35).
- E. Slide bracket (31) away from body until it clears bracket and packing flange mounting studs. Remove lever (32), lever arm (64) and indicator arm (35) from shaft.

CAUTION

Before proceeding determine valve action (air to open/air to close), refer to the appropriate figure (Figure 10 to open, Figure 11 to close). To obtain proper alignment, the lever must be oriented on the shaft so that the slot in the end of the shaft and arrows or indicator lines are aligned as shown; with the ball in the closed position, the distance between the top of the bracket and the top of the pivot pin must be as shown.

- F. Flip lever (32) and lever arm (64) and replace on shaft 90 away from original position. Replace indicator arm (35). Slide bracket back onto bracket mounting studs (26), replace washers (18) and nuts (24) and tighten. Slide packing flange (23) back over packing flange studs (25) and replace packing flange stud nuts (24) and tighten.
- G. Replace actuator on bracket in correct mounting position for air action. Replace actuator stud nuts (75) and washers (76). Position lever (32) and lever arm (64) so that rod end bearing (94) lines up in lever (32). Tighten lever cap screw (33).
- H. Place ball plug (2) in closed position. If actuator action is air to open, loosen rod end bearing nut (93) and adjust position of rod end bearing (94) so that holes in lever (32) and rod end bearing (94) line up. Insert pivot pin (39) and replace retaining rings (40).
- I. If action is air to close, place ball plug (2) in closed position and pneumatically stroke actuator fully.

CAUTION

Do not exceed maximum air supply pressure.

- J. For both air to open and air to close action, stroke valve fully to ensure proper closure of ball plug and operation of valve. Tighten rod end bearing locknut (93).

CAUTION

When stroking valve keep hands and equipment clear of ball plug and seal ring to avoid injury or damage to personnel or equipment.

- K. Replace handwheel bracket (62), cap screws (70) and lockwashers (71) on opposite side of actuator bracket from where originally found. Insert handwheel assembly in bracket and replace clevis pin (66), retaining rings (63), lever arm bearing (65) and pivot pins (72). Replace shaft cover (42) and screw (43).
- L. Set and lock indicator (35) to indicate plug position.

2.5.2 Model 33, size AC only. For sizes B & C refer to section 2.5.1 above.

- A. If the valve is equipped with a handwheel disengage the handwheel and remove retaining clip (54-7) and washer (54-4). Remove handwheel assembly (54) from housing (31) by rotating counter-clockwise.
- B. Remove pivot pin retaining clips (40), pivot pin (39). Remove actuator hex nuts (75) and washers (76). Remove actuator.
- C. Remove cover (48) from opposite side of bracket (31) and install on side actuator was just removed from.
Note: Cover (48) is attached to yoke with contact adhesive that is pre-applied. If a new cover is not available, it can be re-installed by applying contact adhesive to the cover and bracket following the instructions for the specific adhesive used.
- D. Install actuator on opposite side of yoke than it was removed from. Attach using washers (76) and hex nuts (75).

CAUTION

Before proceeding determine valve action (air to open/air to close).

- E. Rotate ball plug (2) to closed position. Verify closed position travel stop (102) contacts the pad on lever (32). Adjust as necessary. Tighten locknut (101).

CAUTION

Ensure rotation of AC actuator does not exceed 90deg. Damage to actuator rod may result.

- F. Rotate ball plug (2) to open position. Verify open position travel stop contacts pad on lever (32). Adjust as necessary. Tighten locknut (101).
- G. If actuator action is air to open, rotate ball plug (2) to open position. Pneumatically stroke actuator to open position. Loosen rod end bearing locknut (93) and adjust position of rod end bearing (94) so that holes in lever (32) and rod end bearing (94) line up. Insert pivot pin (39) and retaining rings (40).

CAUTION

When stroking valve keep hands and equipment clear of ball plug and seal ring to avoid injury or damage to personnel and equipment.

- H. If action is air to close place ball plug (2) in closed position. The pad on lever should contact the closed position travel stop (102). If it does not, repeat adjustment as noted in step I above. Return ball plug (2) to open position.

CAUTION

Do not exceed maximum air supply pressure. Keep hands clear of actuator stem and linkage.

Loosen rod end bearing locknut (93) and adjust rod end bearing (94) so that holes in lever (32) and rod end bearing (94) line up. Insert pivot pin (39) and replace retaining rings (40).

- I. For both air to open and air to close action, stroke valve fully to ensure proper closure of ball plug and operation of valve. It may be necessary to readjust rod end bearing slightly by loosening locknut and rotating stem.
- J. Replace handwheel assembly (54) in bracket (31), washer (54-7) and retaining clip (54-4).
- K. Set and lock indicator arm (35) to indicate plug position.

3.0 MAINTENANCE

3.1 Bracket Subassembly – Model 33, sizes B & C only. Refer to section 3.2 for size AC

3.1.1 Disassembly

CAUTION

When disconnecting actuator rod end bearing from shaft arm, the ball is likely to rotate toward the bottom of the valve body. Keep hands and tools away from the ball.

- A. Remove screw (43) and shaft cover (42) or positioner if so equipped.
- B. Remove retaining clips (40), pivot pin (39) and spacer rings (69).
Note: Spacer rings apply only on handwheel option.
- C. Remove actuator mounting nuts (75) and washers (76) and remove actuator from bracket (31).
- D. If valve has handwheel, remove retainer clips (63), clevis pin (66), pivot pins (72). Remove handwheel assembly from bracket.
- E. Loosen cap screw (33) and indicator arm (35). Remove packing flange stud nuts (24) and bracket mounting stud nuts (26) and washers (18).
- F. Scribe a witness mark on the lever (32) indicating relative position to the slot in the end of the shaft (5).
- G. Slide bracket (31) off studs and shaft, removing indicator arm (35), lever (32), lever arm (64) and packing flange (23).
- H. Remove bearing (47) from bracket. Examine all parts for wear and/or damage. Replace if necessary.

3.1.2 Reassembly

NOTE: If the valve is equipped with a handwheel the lever consists of two separate arms which are a MATCHED PAIR and are not interchangeable with any other pair. The sequence of assembly is to place one lever over the shaft then the lever arm (64) insert pin (68), and then the second lever arm onto the shaft then slide the shaft into the bracket and bearing.

- A. Replace ball bearing (47) in the bracket (31).
- B. Place ball plug (2) in closed position. Slide bracket (31) partially over shaft. Ensure all packing box parts are in place and then slide packing flange (23) onto shaft. Slide lever (32) onto shaft on its former position. Slide handwheel lever arm (64) and second lever (32) onto shaft if valve has handwheel. Replace indicator arm (35). Slide bracket fully onto mounting studs (26); ensure shaft (5) is properly located in bearing (47). Replace lock-washer (18) and bracket mounting stud nuts (24) and tighten. Replace packing flange stud nuts (24).
- C. Pull shaft out to bottom against bearing. Replace actuator and install washers (76) and nuts (75). Slide lever (32) on shaft so that it is lined up with rod end bearing (94). Tighten lever locking screw (33).
- D. If valve action is air to open place ball plug (2) in closed position. Loosen rod end bearing locknut (93) and adjust rod end bearing until holes in lever (32) and rod end bearing (94) line up. Install pivot pin (39), spacers (69) (handwheel only) and retainer rings (40). If valve action is air to close, place ball plug (2) in closed position and pneumatically stroke actuator fully.

CAUTION

Do not exceed maximum air supply pressure specified on the valve nameplate.

- E. For both air to open and air to close action, stroke valve fully to ensure proper closure of ball plug and operation of valve. Tighten rod end bearing locknut (93).

CAUTION

When stroking valve keep hands and equipment clear of ball plug and seal ring to avoid injury or damage to personnel or equipment. Do not exceed pressure specified on the valve nameplate.

- F. Replace shaft cover (42) and screw (43) (or positioner if so equipped).
- G. Replace handwheel assembly in bracket (62) and replace clevis pin (66), retaining clips (63), and pivot pins (72).
- H. Set and lock indicator arm (35) to indicate plug position.
- I. Check that handwheel operates valve through full range of travel. There is a 1/2" adjustment available at the end of the handwheel extension. Retract handwheel, remove end cap (51) and cap screw (55B). Rearrange stop (55A) and/or spacer (55C) to obtain desired extension.

3.2 Bracket Subassembly – Model 33, size AC only. Refer to section 3.1 for sizes B & C

3.2.1 Disassembly

CAUTION

When disconnecting actuator rod end bearing from shaft arm, the ball is likely to rotate toward the bottom of the valve body. Keep hands and tools away from the ball.

- A. Remove screw (43) and shaft cover (42) or positioner if so equipped.
- B. Remove retaining clips (40), pivot pin (39).
- C. Remove actuator mounting nuts (75) and washers (76) and remove actuator from bracket (31).
- D. If valve has handwheel, remove retainer clip (54-7) and washer (54-4). Remove handwheel assembly (54) from bracket.
- E. Loosen cap screw (36) and indicator arm (35). Remove packing flange stud nuts (24) and bracket mounting stud nuts (26) and washers (18).
- F. Scribe a witness mark on the lever (32) indicating relative position to the slot in the end of the shaft (5). Loosen cap screw (11).
- G. Slide bracket (31) off studs and shaft, removing indicator arm (35), lever (32) and packing flange (23).
- H. Remove bearing (47) and grommet (106) from bracket. Examine all parts for wear and/or damage. Replace if necessary.

3.2.2 Reassembly

- A. Replace ball bearing (47) and grommet (106) in the housing (31). Note, the grommet has a recessed area on one side. It should be installed with that side should be toward the inside of the bracket.
- B. Place ball plug (2) in closed position. Slide bracket (31) partially over shaft. Ensure all packing box parts are in place and then slide packing flange (23) onto shaft. Slide lever (32) onto shaft on its former position. Replace indicator arm (35). Slide bracket fully onto mounting studs (26); ensure shaft (5) is properly located in bearing (47). Replace lock-washer (18) and bracket mounting stud nuts (24) and tighten. Replace packing flange stud nuts (24).
- C. Pull shaft out to bottom against bearing. Replace actuator and install washers (76) and nuts (75). Slide lever (32) on shaft so that it is lined up with rod end bearing (94). Tighten lever locking screw (33).
- D. Place ball plug (2) in closed position. If valve action is air to close, pneumatically stroke actuator fully. Loosen rod end bearing locknut (93) and adjust rod end bearing until holes in lever (32) and rod end bearing (94) line up. Install pivot pin (39) and clips (40).

CAUTION

Do not exceed maximum air supply pressure specified on the valve nameplate.

- E. For both air to open and air to close action, stroke valve fully to ensure proper closure of ball plug and operation of valve. Tighten rod end bearing locknut (93).

CAUTION

When stroking valve keep hands and equipment clear of ball plug and seal ring to avoid injury or damage to personnel or equipment. Do not exceed pressure specified on the valve nameplate.

- F. Replace shaft cover (42) and screw (43) (or positioner if so equipped).
- G. Replace handwheel assembly (54) in housing (31) and replace washer (54-4) and retaining clip (54-7).
- H. Set and lock indicator arm (35) to indicate plug position.
- I. Check that handwheel operates valve through full range of travel.

3.3 Body Subassembly

3.3.1 Packing

Note: The packing follower should be held firmly, but not too tightly against the packing.

Overtightening of the packing causes excessive friction and may affect valve operation. The packing in a new V-Max valve has not been tightened prior to shipment. It is recommended that further adjustments be made when the valve is put into service. If necessary to add packing, proceed as follows:

CAUTION

Valve must be isolated and process pressure vented before performing packing box maintenance.

3.3.1.1 Disassembly

- A. Loosen and remove packing flange nuts (24) and slide packing flange (23) and packing follower (20) toward shaft lever (32).

Note: The lever (32) may be disconnected from the actuator stem and pushed up against the shaft bearing (47) (refer to section 3.1), if necessary for clearance.

- B. Using a packing hook, remove the top pieces of packing rings.

3.3.1.2 Reassembly

- A. Install new packing ring(s), making sure the skive cut in adjacent packing rings is offset 120° apart.
- B. Replace packing follower (20) packing box flange (23) and packing nuts (24).
- C. Evenly tighten packing nuts (24).

CAUTION

DO NOT overtighten packing nuts.

- D. Place valve into service and tighten packing nuts (24) only as much as necessary to stop any leakage.

3.3.2 Seal Ring – MN-7 Seal

3.3.2.1 Disassembly

Note: Seal ring removal, inspection and reinstallation must be done with the valve removed from the pipeline.

- A. Remove screws (9) and washers (10), retainer (3), MN-7 seal ring (8) and downstream back-up ring (32).

- B. Remove gasket (4) residue from body and retainer taking care not to damage seal surfaces.

3.3.2.2 Reassembly

- A. Move ball to the closed position.

Note: Use a light coating of Dow-Corning 111® or equal on the ball plug to break in seat.

- B. Replace backup ring (32), seal assembly, gasket (4) and retainer (3). Take care that beveled edges of seal (8) and backup ring (32) are facing the ball.

- C. Replace set screws (9) and washers (10) and tighten.

3.3.3 Seal Ring – Standard Metal Seal

3.3.3.1 Disassembly

Note: Seal ring removal, inspection and reinstallation must be done with the valve removed from the pipeline.

- A. Remove screws (9) and washers (10).

Note: The flexible metal seal assembly consists of a seal ring (8), gasket (7), and backup ring (6).

- B. Mark flexible metal seal ring (8) so that, if reinstalled, the same side will be in contact with the ball. Remove retainer, seal assembly and downstream back-up ring (32). If difficulty is encountered in removing seal assembly, rotate the ball to open position and pull out the seal ring.

- C. Remove gasket (4) residue from body and retainer taking care not to damage seal surfaces.

3.3.3.2 Reassembly

Note: If retrofitting a valve originally equipped with an MN-7 seal ring follow steps A through D. If valve was originally supplied with a metal seal, please proceed to step C.

- A. Clean the contact surfaces of the ball plug (2) with alcohol or other suitable degreaser to facilitate application of the dry graphite spray lubricant. If necessary, very mild abrasive pads such as Scotch-Brite™ may be used to remove any oxide layers on the ball plug (2).

- B. Apply the dry graphite lubricant spray (Dow-Corning 321®) in several light coats on the plated seal contact surfaces of the ball plug (2). Allow the graphite spray to dry fully – which will produce a dull gray finish on the coated parts.

- C. Move ball to the closed position.

- D. Replace downstream back-up ring (32), seal assembly, gasket (4) and retainer (3). Take care that beveled edge flexible metal seal (8) and backup rings (6 & 32) are facing the ball.

- E. Replace set screws (9) and washers (10) and tighten.

3.3.4 Seal Ring – Heavy Duty Metal Seal

3.3.4.1 Disassembly

Note: Seal ring removal, inspection and reinstallation must be done with the valve removed from the pipeline.

- A. Remove screws (9) and washers (10).

Note: The Heavy Duty Metal Seal assembly consists of a seal ring (8), radial seal (30) and wave spring (31).

- B. Note the orientation of the radial seal (30) and wave washer (31) for reassembly.
- C. Clean parts of any residue that remains from the process. Take care not to damage or mark the sealing surfaces of seal ring (8) or radial seal (30).

3.3.4.2 Reassembly

Note: If retrofitting a valve originally equipped with an MN-7 seal ring follow steps A through D. If valve was originally supplied with a metal seal, please proceed to step C.

- A. Clean the contact surfaces of the ball plug (2) with alcohol or other suitable degreaser to facilitate application of the dry graphite spray lubricant. If necessary, very mild abrasive pads such as Scotch-Brite™ may be used to remove any oxide layers on the ball plug (2).
- B. Apply the dry graphite lubricant spray (Dow-Corning 321®) in several light coats on the plated seal contact surfaces of the ball plug (2). Allow the graphite spray to dry fully – which will produce a dull gray finish on the coated parts.
- C. Move ball to the closed position
- D. Lubricate the Radial Seal (30) with Dow-Corning 111® Silicon grease (or equivalent) and install it over the end of the Heavy Duty Seal Ring (8).
Note: The open lips of the radial seal (30) must face AWAY from the seat bevel and ball.
- E. Install the Wave Spring (31) over the end of the Heavy Duty Seal Ring (8).
- F. Insert the Seat Retainer (3) over the end of the Seat (8) and apply even pressure to overcome the resistance of the radial seal (30) until the wave spring (31) is compressed.
- G. Install the retainer/body gasket (4).
- H. Install the seat (8), retainer (3), radial seal (101) and wave spring (102) assembly into the body counter-bore until contact is made with the ball plug (2).
- I. Install retainer screws (9) and washers (1) and tighten to secure the retainer and seal assembly in the body.

3.3.5 Ball Plug

3.3.5.1 Ball Plug Disassembly

- A. Remove bracket (see section 3.3.2).
- B. Remove screws (9) and washers (10). Slide the retainer (3) out of the valve body. Remove seal assembly (refer to Para. 3.2.2.1 Seal Ring - Disassembly).
- C. Remove safety pin (27). Remove the shaft (5) from the valve body. The packing (19), packing adaptor (28) and packing follower (20) will slide out with the shaft. If the shaft will not move, thread nuts (24) on the packing studs, then place the packing flange (23) on top of the nuts. Slide the lever (32) onto the shaft (5) up against the packing flange (23) and tighten screw (34).

By unscrewing the packing nuts (24) evenly, ample force is developed to move the shaft (5). Once shaft has been started, it should be possible to remove the shaft completely. If not, a suitable size bolt screwed into the tapped hole on the shaft end can be used as a shaft “puller”.

- D. Remove nuts (13), end flange (14), pin shaft (11) and gasket (15). If the pin shaft will not move, push it out with a rod inserted through the bonnet end of the valve.
- E. Remove the ball (2) and separate the lower bushing (16) from it. Remove the upper bushing (17). If it sticks, the upper bushing (17) can be pushed out with a rod of suitable size inserted into the pin shaft end of the body.
- F. Examine all parts for damage due to erosion, corrosion, or wear. Replace the seal ring if damaged, worn or distorted. Replace all defective parts and all packing and gaskets. Clean the valve parts thoroughly before reassembly. Remove gasket (4) and (15) residue from body and retainer taking care not to score sealing areas.

3.3.5.2 Ball Plug Reassembly

Note: If installing a new ball plug into a valve equipped with either the standard metal or Heavy Duty metal seal rings, the ball plug must be first coated with dry graphite lubricant as described in steps A and B. If equipped with an MN-7 seal ring, proceed to step C.

- A. Clean the contact surfaces of the ball plug (2) with alcohol or other suitable degreaser to facilitate application of the dry graphite spray lubricant. If necessary, very mild abrasive pads such as Scotch-Brite™ may be used to remove any oxide layers on the ball plug (2).
- B. Apply the dry graphite lubricant spray (Dow-Corning 321®) in several light coats on the plated seal contact surfaces of the ball plug (2). Allow the graphite spray to dry fully – which will produce a dull gray finish on the coated parts.
- C. Replace lower bushing (16) in the ball and position ball in the body. Replace gasket (15).
- D. Lubricate pin shaft (11) and insert through body and into the ball. Secure with end flange (14) and end flange nuts (13). Tighten nuts alternately to assure tight seal against the gasket. (Recommended lubricant SAF-T-EZE Anti-Seize or equal.)
- E. Replace ring (29), and upper bushing (17) on the shaft (5). Install shaft in the body and engage the ball such that when the ball is in the closed position, the machined slot in the shaft end is vertical (perpendicular to the body axis). Coat shaft below ring groove and bushing with lubricant (SAF-T-EZE Anti-Seize or equal).
- F. Install packing adaptor (28), bevel side out over the shaft (5) and into the valve bonnet so that the hole through the side of the adaptor is aligned with the tapped hole through the bonnet for the safety pin (27).
- G. Apply pipe sealant to the safety pin, install into bonnet and tighten.

CAUTION

Safety pin must engage hole in packing adaptor. Test by manually pulling on shaft to verify pin engagement.

- H. Install packing (19) so that skive cut of each piece of packing is offset approximately 120° from that of adjacent piece.
- I. Install packing follower (22) over shaft and into bonnet with bevel side out. Install packing box flange (23) and nuts (24).
- J. Install seal ring and retainer assembly as described in section 3.3.2, 3.3.3 or 3.3.4 depending on seal type.
- K. Install mounting bracket (31) and lever (32). Follow instruction 3.1.2 Bracket Reassembly.
- L. Evenly tighten packing flange nuts (24) against packing flange (23) before placing valve into service.

CAUTION

DO NOT over tighten packing flange nuts. After valve has been in service, retighten packing flange nuts evenly until any leaks are stopped.

3.4 Actuator Subassembly.

3.4.1 Model 33, sizes B & C. Refer to section 3.7 for size AC actuators.

3.4.1.1 Disassembly

CAUTION

The upper diaphragm case (84) is under spring tension. A warning tag (97) is attached to each of the three (3) long cap screws (95). The tension nuts (96) attached to cap screws (95) must be evenly removed last. The following procedure must be followed to avoid injury.

- A. Isolate the valve, vent process pressure and shut off all electrical, signal air and supply air lines to the valve.
- B. If equipped with a handwheel, it must be rotated to the disengaged position.
- C. Remove air supply piping to upper diaphragm case (84).
- D. Remove side covers (46).
- E. Remove retaining clips (40) and remove pivot pin (39) and spacers (69) (handwheel only) to free rod end bearing (94).
- F. Loosen and remove all short cap screws (86) and hex nuts (87). Mark upper case (84) and lower case (20) so that they can be reassembled with the same orientation of air inlet and mounting bolts.
- G. Loosen each tension nut (96) approximately three full turns.

CAUTION

The upper diaphragm case (84) should separate from the lower case (91) as the tension nuts are loosened the three turns. If it does not, before proceeding, separate the upper diaphragm case (84) by tapping it around the circumference or inserting a screwdriver between the upper (84) and lower case (91). If the cases still do not separate, check that the actuator stem is not hung up inside the bracket. **DO NOT PROCEED WITH DISASSEMBLY UNLESS THE CASES CAN SEPARATE FREELY.**

- H. Continue loosening the tension nuts (96) evenly approximately three turns each time ensuring that the upper diaphragm case (84) and diaphragm (85) continue to separate.

Note: Continue Step H until the tension nuts (96) can be easily removed by hand indicating the upper diaphragm case (84) is not under spring tension.

- I. Remove tension bolts (95) and upper diaphragm case (84).
- J. Remove diaphragm (85) and diaphragm plate subassembly from the actuator.
- K. Remove retaining clip (78). Remove clevis pivot pin (79). Inspect for damage and/or wear in clevis (80), lever (32), clevis pins (79, 39) and rod end bearings (94). Replace if necessary.
- L. Clean all mating/sealing surfaces which will come in contact with the diaphragm (85).

3.4.1.2 Reassembly

- A. Connect rod end bearing (94) to diaphragm plate clevis (80) by installing clevis pin (79) and retaining clips (78). Ensure that the stem (77) is installed such that the wrench flats are at the end furthest from the diaphragm plate (88).
- B. Ensure spring (90) and spring guide (89) are properly aligned in lower case (91) and install the diaphragm plate and stem subassembly. Replace diaphragm (85).
- C. Align marks for correct orientation of upper case (84) and lower case (91). Replace upper diaphragm case (84) and install long cap screws (95), warning plate (97) and tension nuts (96).

Note: These bolts must be equally spaced at 120° intervals.

- D. Take up tension nuts (96) evenly and sufficiently to allow installation of short cap screws (83) and hex nuts (87).
- E. Tighten tension nuts (96) and then tighten all hex nuts (87) using a criss-cross tightening pattern.

Note: Nuts should be tightened only enough to seal the diaphragm between the upper and lower case. Do not overtighten.

- F. Connect rod end bearing (94) to lever (32) by installing pivot pin (39), spacers (69) (handwheel only), and retaining clips (40).
- G. Replace side covers (46) and reconnect signal and supply lines.

- H. Place back in service and, if so equipped, rotate handwheel to desired position.

3.4.2 Actuator Subassembly – Model 33, size AC. Refer to section 3.4.1 for sizes B & C. Figures 13, 14, 15 & 16.

3.4.2.1 Disassembly

CAUTION

The upper diaphragm case (84) is under spring tension. A warning tag (97) is attached to each of the three (3) long cap screws (95). The tension nuts (96) attached to cap screws (95) must be evenly removed last. The following procedure must be followed to avoid injury.

- A. Isolate the valve, vent process pressure and shut off all electrical, signal air and supply air lines to the valve.
- B. If equipped with a handwheel, it must be rotated to the disengaged position.
- C. Remove air supply piping to upper diaphragm case (84).
- D. Remove covers (44 & 46).
- E. Remove retaining clips (40) and remove pivot pin (39) to free rod end bearing (94).
- F. Loosen and remove all short cap screws (86) and hex nuts (87). Mark upper case (84) and lower case (91) so that they can be reassembled with the same orientation of air inlet and mounting bolts.
- G. Loosen each tension nut (95) approximately three full turns.

CAUTION

The upper diaphragm case (84) should separate from the lower case (91) as the tension nuts are loosened the three turns. If it does not, before proceeding, separate the upper diaphragm case (84) by tapping it around the circumference or inserting a screwdriver between the upper (84) and lower case (91). If the cases still do not separate, check that the actuator stem is not hung up inside the bracket. **DO NOT PROCEED WITH DISASSEMBLY UNLESS THE CASES CAN SEPARATE FREELY.**

- H. Continue loosening the tension nuts (95) evenly approximately three turns each time ensuring that the upper diaphragm case (84) and diaphragm (85) continue to separate.

Note: Continue Step H until the tension nuts (95) can be easily removed by hand indicating the upper diaphragm case (84) is not under spring tension.

- I. Remove tension bolts (95) and upper diaphragm case (84).
- J. Remove diaphragm (85) and diaphragm plate subassembly from the actuator.
- K. Remove retaining clip (78). Remove clevis pivot pin (79). Inspect for damage and/or wear in clevis (80), lever (32), clevis pins (79, 39) and rod end bearings (94). Replace if necessary.

- L. Clean all mating/sealing surfaces which will come in contact with the diaphragm (85).

3.4.2.2 Reassembly

- A. Connect rod end bearing (94) to diaphragm plate clevis (80) by installing clevis pin (79) and retaining clips (78). Ensure that the stem is installed such that the wrench flats are at the end furthest from the diaphragm plate (88).
- B. Ensure spring (90) and spring guide (98) are properly aligned in lower case (91) and install the diaphragm plate and stem subassembly. Replace diaphragm (85).
- C. Align marks for correct orientation of upper case (84) and lower case (91). Replace upper diaphragm case (84) and install long cap screws (95), warning plate (97) and tension nuts (96).

Note: These bolts must be spaced as equally as possible.

- D. Take up tension nuts (96) evenly and sufficiently to allow installation of short cap screws (86) and hex nuts (87).
- E. Tighten tension nuts (96) and then tighten all hex nuts (87) using a criss-cross tightening pattern.

Note: Nuts should be tightened only enough to seal the diaphragm between the upper and lower case. Do not overtighten.

- F. Connect rod end bearing (94) to lever (32) by installing pivot pin (39), and retaining clips (40).
- G. Replace covers (44 & 46) and reconnect signal and supply lines.
- H. Place back in service and, if so equipped, rotate handwheel to desired position.

3.5 Handwheel Subassembly

3.5.1 Model 33 sizes B & C only. Refer to section 3.5.2 for size AC actuators.

3.5.1.1 Disassembly

CAUTION

Turn handwheel to disengage position before proceeding with handwheel maintenance. Refer to Figures 13 through 16.

- A. Remove retaining clips (63) and push out pin (66). Make sure bushing (65) remains in the arm (64).
- B. Remove the pivot pins (72) and remove handwheel subassembly.
- C. Remove handwheel shaft subassembly (55) retaining ring (59) and unscrew nut (58). Remove needle bearing and race (60). Clean and check needle bearing and race for signs of wear. Replace if necessary.
- D. Remove handwheel pivot (56) and thrust washer (61). Check washer and replace if necessary. Check O-ring (57) and replace if necessary.
- E. Clean ACME threads on handwheel (54) and shaft S/A (55) and grease with Molykote G.

3.5.1.2 Reassembly (Figure 5)

- A. Install thrust washer (61) and O-ring (57). Apply silicone lubricant sparingly to O-ring.
- B. Slide handwheel pivot (56) onto the handwheel subassembly. Lubricate and install bearing race, needle bearing and outer race.
- C. Install nut (58) bevel side toward bearing race and screw down tight. DO NOT OVERTIGHTEN. Replace retaining ring (59). Correct assembly should have the nut (58) touching the retaining ring (47).

CAUTION

Do not rotate handwheel prior to replacing pivot pins (72) into the handwheel mounting bracket (62).

- D. Install assembly into handwheel mounting bracket (62) and replace pivot pins (72).
- E. Connect handwheel shaft S/A (55) to handwheel (54) and to the lever arm with pin (66) and replace clip (63).

3.5.2 Handwheel Subassembly – Model 33, Size AC. Refer to section 3.5.1 for sizes B & C. Refer to Figures 13, 14 & 16.

3.5.2.1 Disassembly

CAUTION

Turn handwheel to disengage position before proceeding with handwheel maintenance.

- A. Remove retaining ring (54-7) and shaft washer (54-4).
- B. Rotate Handwheel (54) counterclockwise until it is removed from housing (31).
- C. Clean ACME threads on handwheel shaft (54-3) and grease with Molykote G.

3.5.2.2 Reassembly. Refer to Figures 13, 14 & 16.

- A. Thread handwheel assembly (54) into housing (31) until it extends through the housing and the groove in the stem (54-3) is visible.
- B. Place shaft washer (54-4) over stem (54-3).
- C. Install retaining ring (54-7) into groove on stem (54-3).

3.6 Diaphragm Replacement

WARNING

Spring diaphragm actuators contain large forces due to their preloaded powerful springs. Failure to carefully follow this procedure can result in personal injury!

3.6.1 Model 33 sizes B & C only. Refer to section 3.6.2 for size AC actuators.

3.6.1.1 Disassembly

- A. Relieve actuator pressure and disconnect air supply. Do not remove pivot pin (39).

- B. Verify that all three tension bolts (95) and nuts (96) are in place and secure.
- C. Remove nuts (87) and cap screws (86) following a criss-cross pattern.
- D. Verify actuator stem (77) and rod end (94) are securely connected to lever (32) through pivot pin (39) and that retaining clips (40) are in place.
- E. Loosen tension nuts (96) evenly in sequence. Do not exceed three turns of any one nut (96) before proceeding to the next one. Do not vary the sequence.

WARNING

Failure to evenly unload tension nuts may result in personal injury!

- F. Continue loosening tension nuts (96) until further loosening of the tension nuts (96) is no longer accompanied by an increase in separation of the upper diaphragm case (84) from the lower case (91). At this point the tension nuts (96), bolts (95) and warning plates (97) can be removed.
- G. Remove the upper diaphragm case (84) and diaphragm (85).

CAUTION

The diaphragm plate (88) remains under spring load.

3.6.1.2 Reassembly

- A. Ensure that sealing surfaces of diaphragm cases (84) and (91) are clean and free of any dirt or debris. Check that there are no foreign objects that may interfere with travel or damage diaphragm.
- B. Install diaphragm (85) on diaphragm plate (88). Align bolt holes with holes in lower case (91).
- C. Install three tension bolts (95) with warning plates (97) into upper case (84). Ensure bolts are equally spaced at 120° to each other.
- D. Mount upper case (84) onto diaphragm plate (88) such that the tension bolts pass through holes in diaphragm (85) and lower case (91).
- E. Install tension nuts (96) finger tight onto tension bolts (95).
- F. Tighten each tension nut (96) three turns before proceeding to the next to ensure actuator spring (90) is evenly loaded. Continue until the diaphragm is firmly sandwiched between the flanges of the upper and lower diaphragm cases. Torque tighten tension bolts to 50 in. lbs.
- G. Install cap screws (86) and nuts (87). Torque tighten to 50 in. lbs. in a criss-cross pattern. As this will tend to unload the tension bolts (96) repeat torque tightening of tension bolts and cap screws (86) to 50 in. lbs. in a criss-cross pattern until joint is evenly loaded to specified torque values.
- H. Reconnect air supply.
- I. Stroke actuator to confirm operation.

3.6.2 Model 33 size AC actuators only. Refer to section 3.6.1 for sizes B & C.

3.6.2.1 Disassembly

- A.** Relieve actuator pressure and disconnect air supply. Do not remove pivot pin (39).
- B.** Verify that all three tension bolts (95) and nuts (96) are in place and secure.
- C.** Remove nuts (87) and cap screws (86) following a criss-cross pattern.
- D.** Verify actuator stem (15) and rod end (94) are securely connected to lever (32) through pivot pin (39) and that retaining clips (40) are in place.
- E.** Loosen tension nuts (96) evenly in sequence. Do not exceed three turns of any one nut (96) before proceeding to the next one. Do not vary the sequence.

! WARNING

Failure to evenly unload tension nuts may result in personal injury!

- F.** Continue loosening tension nuts (96) until further loosening of the tension nuts (96) is no longer accompanied by an increase in separation of the upper diaphragm case (84) from the lower case (91). At this point the tension nuts (96), bolts (95) and warning plates (97) can be removed.
- G.** Remove the upper diaphragm case (84) and diaphragm (85).

CAUTION

The diaphragm plate (88) remains under spring load.

3.6.2.2 Reassembly

- A.** Ensure that sealing surfaces of diaphragm cases (84) and (91) are clean and free of any dirt or debris. Check that there are no foreign objects that may interfere with travel or damage diaphragm.
- B.** Install diaphragm (85) on diaphragm plate (88). Align bolt holes with holes in lower case (91).
- C.** Install three tension bolts (95) with warning plates (97) into upper case (84). Ensure bolts are equally spaced around the circumference of the case.
- D.** Mount upper case (84) onto diaphragm plate (88) such that the tension bolts pass through holes in diaphragm (85) and lower case (91).
- E.** Install tension nuts (96) finger tight onto tension bolts (95).
- F.** Tighten each tension nut (86) three turns before proceeding to the next to ensure actuator spring (90) is evenly loaded. Continue until the diaphragm is firmly sandwiched between the flanges of the upper and lower diaphragm cases. Torque tighten tension bolts to 50 in. lbs.

- G.** Install cap screws (86) and nuts (87). Torque tighten to 50 in. lbs. in a criss-cross pattern. As this will tend to unload the tension bolts (95) repeat torque tightening of tension bolts and cap screws (86) to 50 in. lbs. in a criss-cross pattern until joint is evenly loaded to specified torque values.
- H.** Reconnect air supply.
- I.** Stroke actuator to confirm operation.

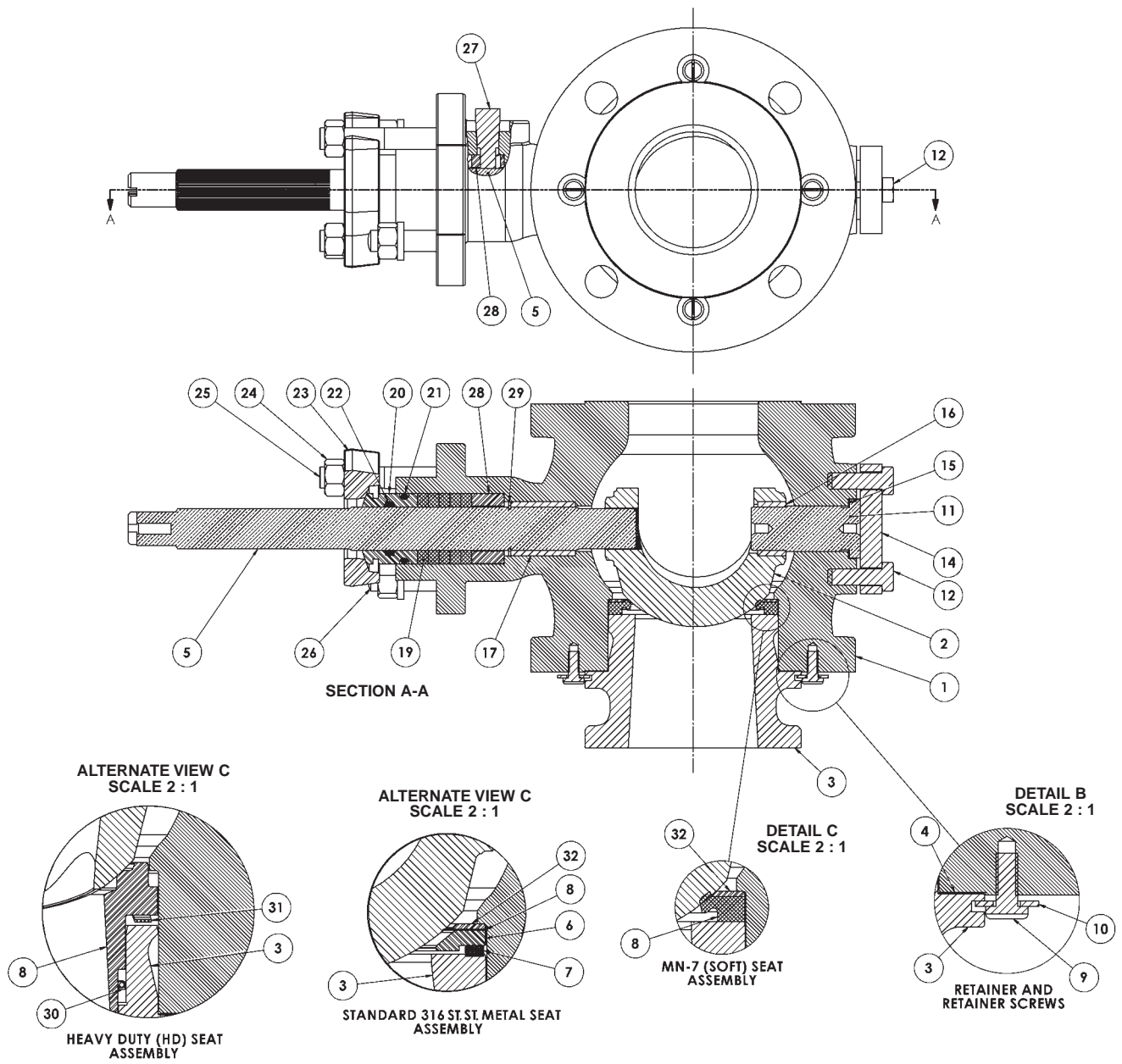

Figure 2 - General Assembly

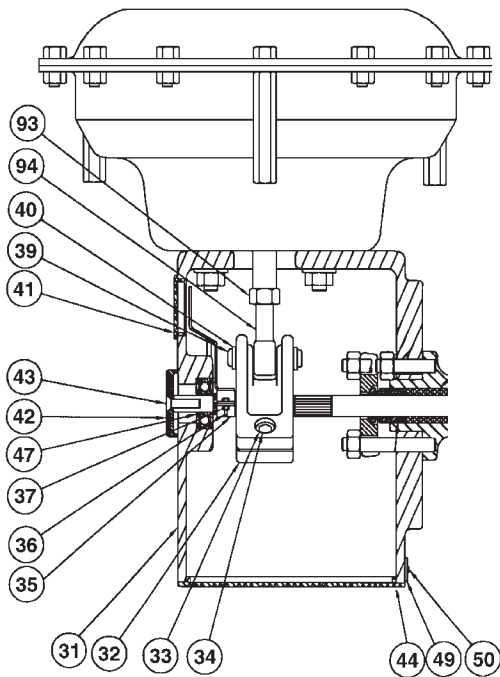

Figure 3 - Sizes B & C Bracket and Linkage

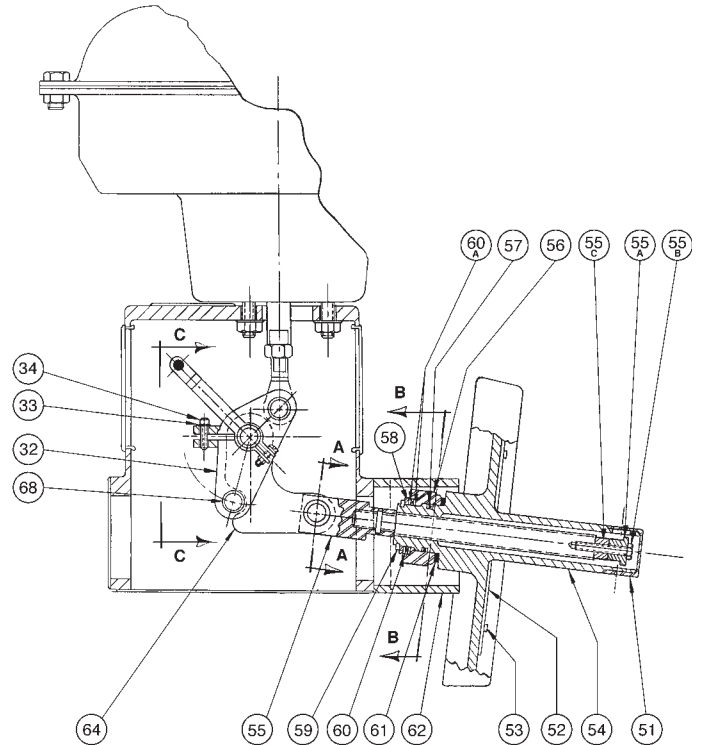

Figure 4 - Handwheel General Assembly, Actuator Sizes B & C

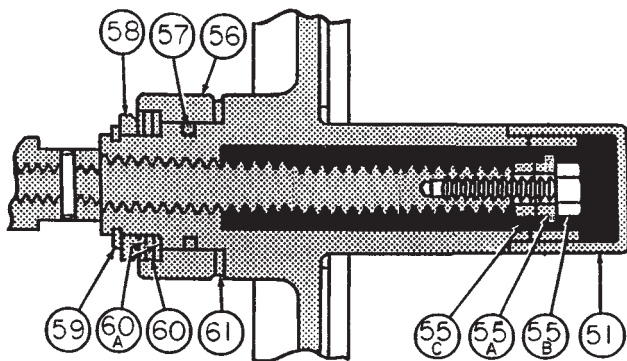

Figure 5 - Handwheel Detail, Actuator Sizes B & C

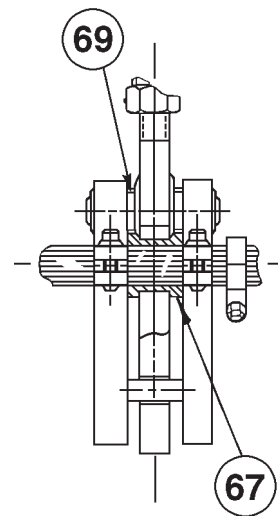

Figure 7 - Handwheel Lever Detail, Actuator Sizes B & C

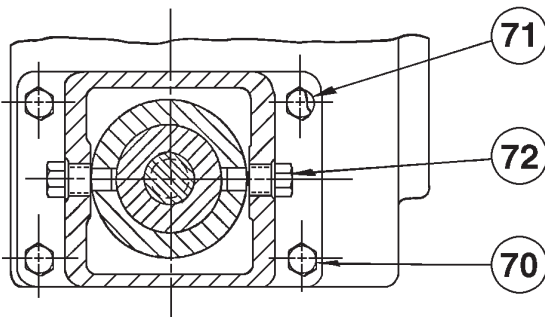

Figure 6 - Handwheel Bracket Detail, Actuator Sizes B & C

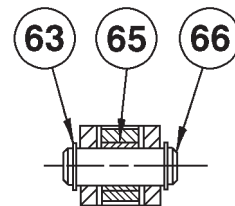
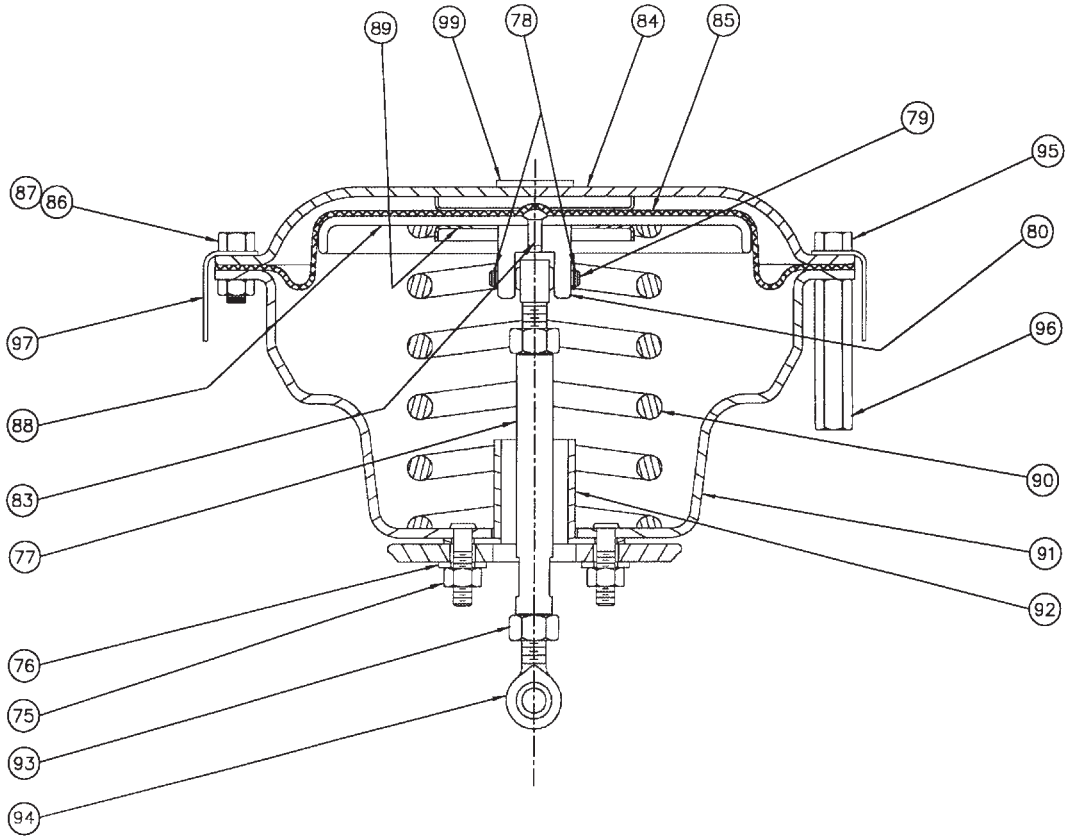
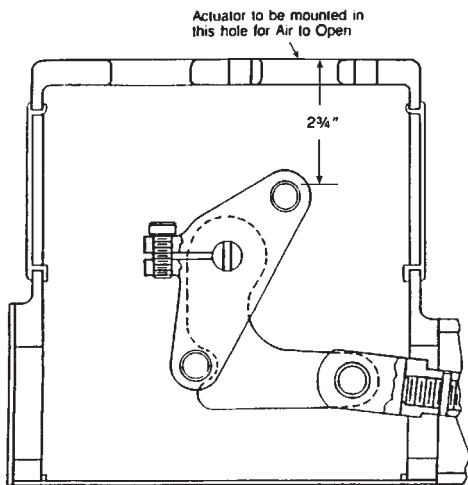

Figure 8 - Handwheel Clevis Detail, Actuator Sizes B & C



**Figure 9 - Actuator General Assembly,
Actuator Sizes B & C**



**Figure 10 - Lever Position Air to Open,
Actuator Sizes B & C**

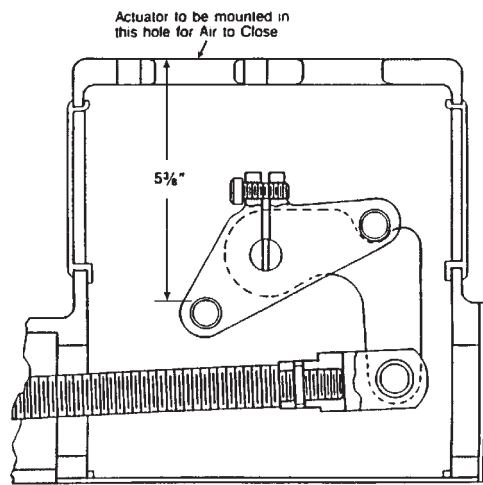

**Figure 11 - Lever Position Air to Close,
Actuator Sizes B & C**

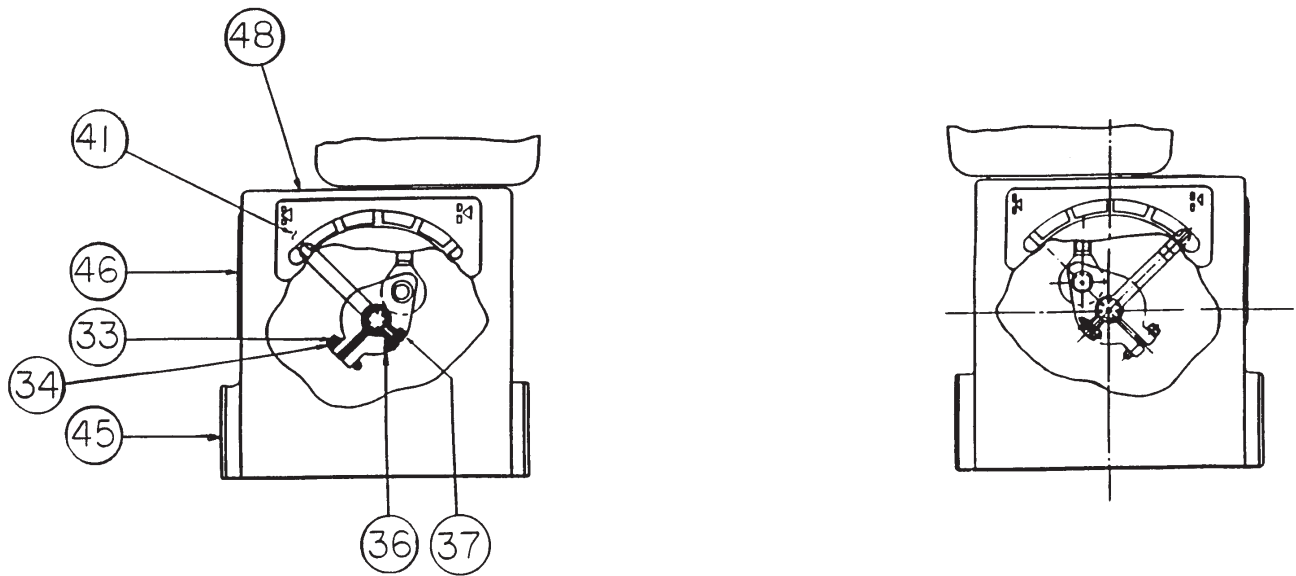

**Figure 12 - Position Indicator Detail,
Actuator Sizes B & C**

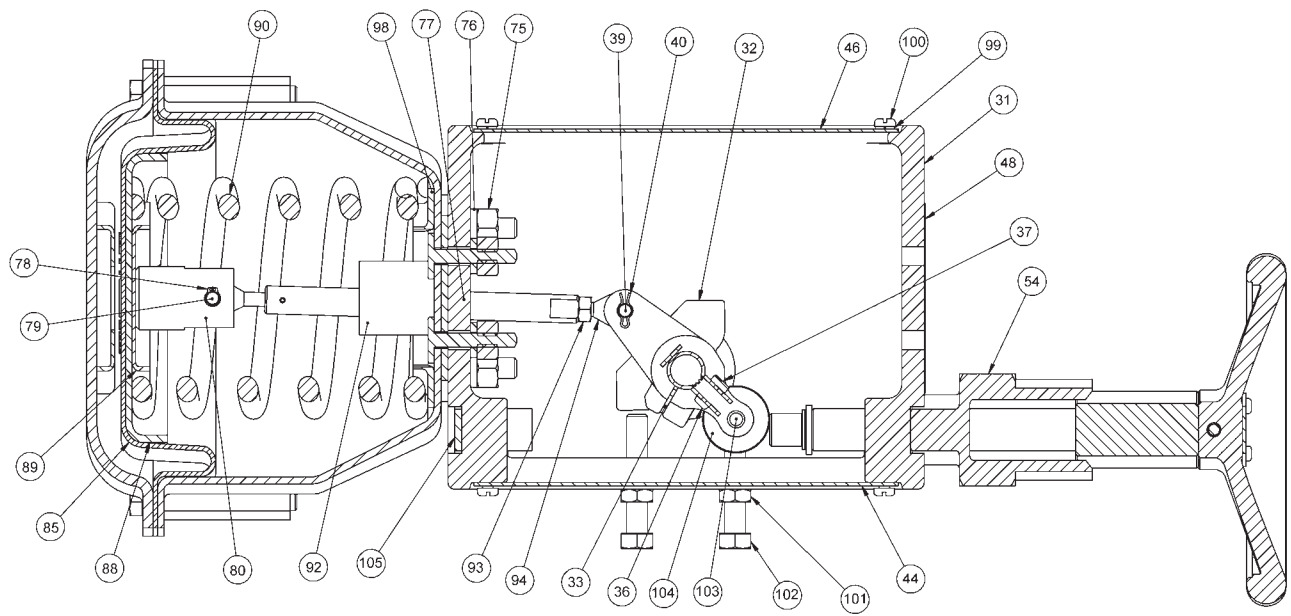

Figure 13 - Size AC Actuator

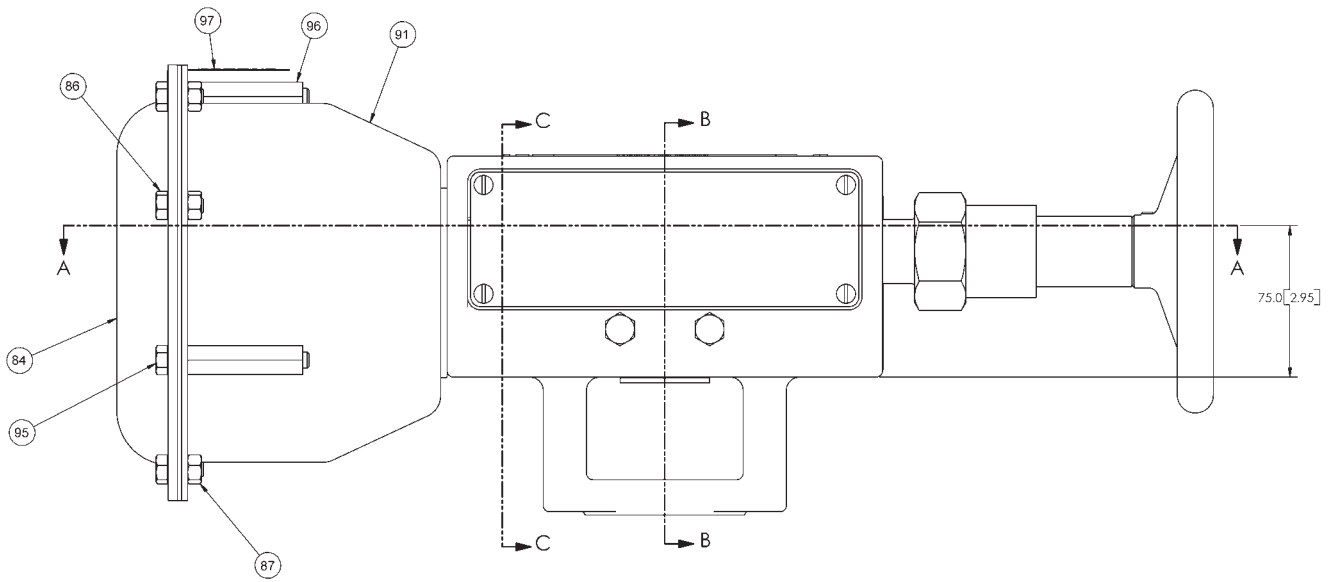

Figure 14 - Size AC Actuator Bottom View

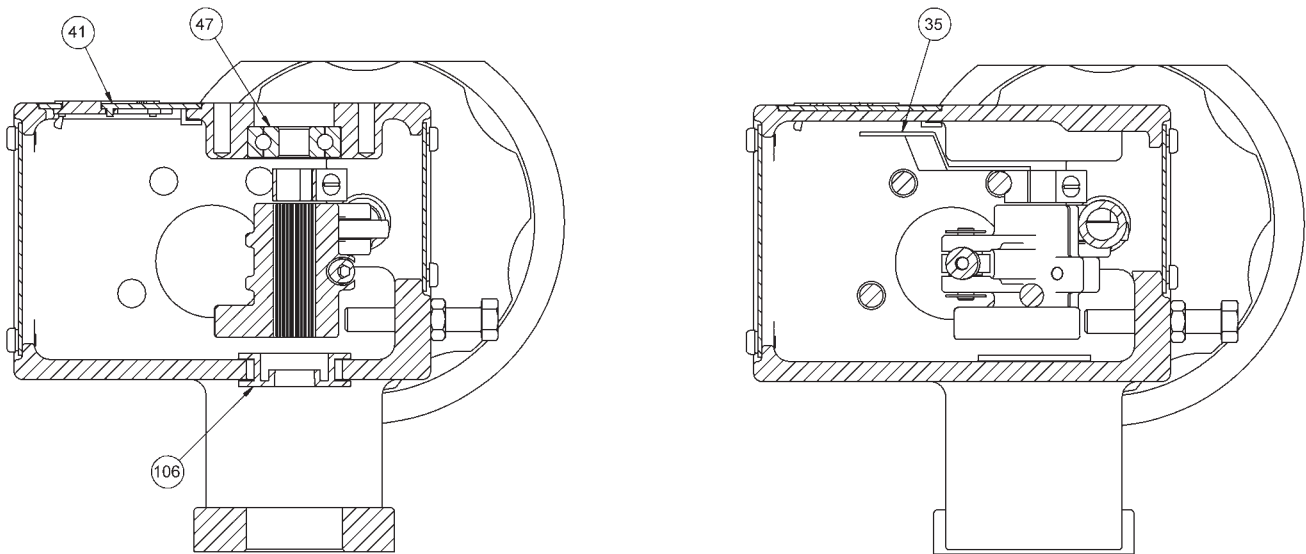

Figure 15 - Size AC Actuator Linkage Detail

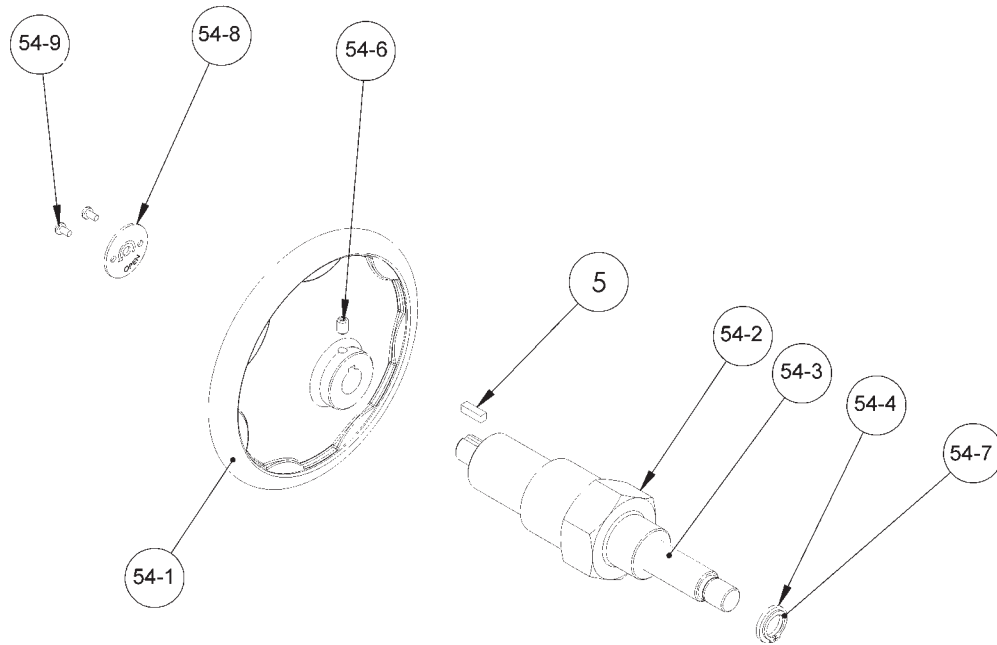

Figure 16 - Handwheel Assembly, Size AC Actuator

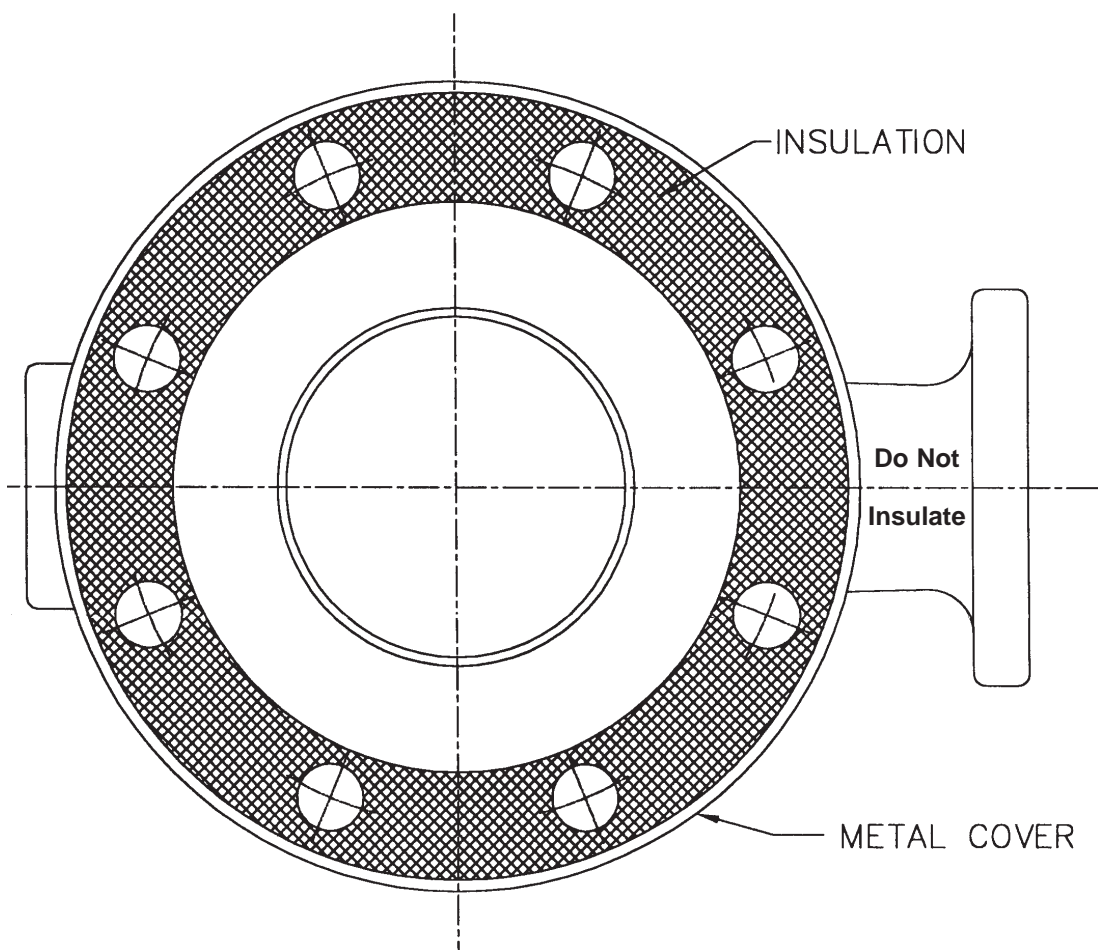

Figure 17 - Insulation detail

Table 1 – Body Parts List

Ref. No.	Description
1	Body
2	Ball Plug
3	Retainer (ISA S75.04)
	Retainer (ANSI B16.10)
4	Gasket (Retainer/Body)
5	Shaft
6	Backup Ring (Std. Metal Seal)
7	Gasket (Std. Metal Seal)
8	Seal Ring
9	Slot Button Head Screw
10	Flat Washer
11	Pin Shaft
12	Stud, End Flange
13	Nut, End Flange
14	End Flange
15	Gasket, Pin Shaft
16	Lower Bushing
17	Upper Bushing
18	Lockwasher
19	Packing
20	Packing Follower
21	O-Ring
22	O-Ring
23	Packing Box Flange
24	Nut, End Flange
25	Stud, Packing Flange
26	Stud, Bonnet
27	Safety Pin
28	Packing Adapter
29	Shaft Ring
30	Radial Seal
31	Wave Spring
32	Backup Ring

Table 2 – Bracket and Linkage Parts List

Ref. No.	Description
33	Cap Screw
34	Lockwasher
35	Indicator Arm
36	Machine Screw
37	Hex Nut
38	Indicator Dot
39	Pivot Pin
40	Retaining Clip
41	Front Cover S/A
42	Shaft Cover
43	Machine Screw
44	Bottom Cover
45	Boss Cover
46	Side Cover
47	Bearing
48	Hole Cover
49	Yoke
50	Lever
99	Lockwasher
100	Screw
101	Hex Nut
102	Adjusting Screw
103	Pin
104	Roller
105	Thread Plug

Table 3 – Handwheel Parts List

Ref. No.	Description
32	Lever Set
33	Lockwasher
34	Cap Screw
51	End Cap
52	Plate
53	Screw
54	Handwheel S/A
54-1*	Handwheel
54-2*	Lock, Handwheel
54-3*	Handwheel Shaft
54-4*	Washer
54-5*	Key
54-6*	Screw
54-7*	Retaining Ring
54-8*	Handwheel Plate
54-9*	Screw
55	Handwheel Shaft S/A
55A	Handwheel Stop
55B	Cap Screw
55C	Spacer
56	Handwheel Pivot
57	O-Ring
58	Locknut
59	Retaining Ring
60	Needle Bearing
60A	Bearing Race
61	Thrust Washer
62	Handwheel Bracket
63	Retaining Clip
64	Lever Arm
65	Lever Arm Bearing
66	Clevis Pin
67	Guide
68	Lever Arm Pin
69	Spacer
70	Cap Screw
71	Lockwasher
72	Pivot Pin

* Size AC Actuator Only

Table 4 – Actuator Parts List

Ref. No.	Description
75	Hex Nut
76	Lockwasher
77	Stem
78	Clip
79	Clevis Pin
80	Clevis
83	Button Head Cap Screw
84	Upper Diaphragm Case
85	Diaphragm
86	Cap Screw
87	Nut
88	Diaphragm Plate
89	Spring Guide
90	Spring
91	Lower Diaphragm Case
92	Stop
93	Nut
94	Rod End Bearing
95	Tension Bolt
96	Tension Nut
97	Warning Plate
98	Spring Button

Table 5 – Line Bolting (Inlet Side)

Size		ANSI Pressure Rating	ISA S75.04 Face to Face		ANSI B16.10 Short Pattern Face to Face	
in	DN		in	mm	in	mm
1	25	150	2 1/2"	64	3 1/2"	89
		300	3"	76	–	–
1-1/2	40	150	3"	76	5"	130
		300	3 1/2"	89	–	–
2	50	150	3 3/4"	95	5 1/2"	140
		300	4"	100	–	–
3	80	150	4"	100	5 1/4"	134
		300	4 3/4"	121	–	–
4	100	150	4"	100	5 1/4"	134
		300	5"	130	–	–
6	150	150	4 1/2"	114	6"	153
		300	6"	153	–	–
8	200	150	4 3/4"	121	6 3/4"	172
		300	6"	153	–	–
10	250	150	5 1/4"	134	6 1/2"	165
		300	7"	178	–	–
12	300	150	5 1/2"	140	6"	153
		300	7 1/2"	191	–	–

Notes



Notes

DIRECT SALES OFFICE LOCATIONS

BELGIUM

Phone: +32-2-344-0970
Fax: +32-2-344-1123

BRAZIL

Phone: 55-11-2146-3600
Fax: 55-11-2146-3610

CANADA

Ontario
Phone: 905-335-3529
Fax: 905-336-7628

CHINA

Phone: +86-10-8486-4515
Fax: +86-10-8486-5305

FRANCE

Courbevoie
Phone: +33-1-4904-9000
Fax: +33-1-4904-9010

GERMANY

Viersen
Phone: +49-2162-8170-0
Fax: +49-2162-8170-280
Frankfurt
Phone: +49-69-439350
Fax: +49-69-4970802

INDIA

Mumbai
Phone: +91-22- 8354790
Fax: +91-22-8354791

New Delhi

Phone: +91-11-2-6164175
Fax: +91-11-5-1659635

ITALY

Phone: +39-081-7892-111
Fax: +39-081-7892-208

JAPAN

Chiba
Phone: +81-43-297-9222
Fax: +81-43-299-1115

KOREA

Phone: +82-2-2274-0748
Fax: +82-2-2274-0794

KUWAIT

Phone: +965-9061157
Fax: +965-3987879

MALAYSIA

Phone: +60-3-2161-0322
Fax: +60-3-2163-6312

MEXICO

Phone: 52-5-310-9863
Fax: 52-5-310-5584

THE NETHERLANDS

Phone: +31-10-438-4122
Fax: +31-10-438-4443

RUSSIA

Veliky Novgorod
Phone: +7-8162-15-7898
Fax: +7-8162-15-7921
Moscow
Phone: +7 495-585-1276
Fax: +7 495-585-1279

SAUDI ARABIA

Phone: +966-3-341-0278
Fax: +966-3-341-7624

SINGAPORE

Phone: +65-6-6861-6100
Fax: +65-6-6861-7172

SOUTH AFRICA

Phone: +27-11-452-1550
Fax: +27-11-452-6542

SOUTH & CENTRAL AMERICA AND THE CARIBBEAN

Phone: 832-590-2303
Fax: 832-590-2529

SPAIN

Phone: +34-93-652-6430
Fax: +34-93-652-6444

UNITED ARAB EMIRATES

Phone: +971-4-8838-752
Fax: +971-4-8838-038

UNITED KINGDOM

Uxbridge
Phone: +44-1895-454-900
Fax: +44-1895-454-919

UNITED STATES

Massachusetts
Phone: 508-586-4600
Fax: 508-427-8971

Corpus Christi, Texas
Phone: 361-881-8182
Fax: 361-881-8246

Dresser Direct
Deer Park, Texas
Phone: 281-884-1000
Fax: 281-884-1010

(Contractor Sales)
Houston, Texas
Phone: 832-590-2303
Fax: 832-590-2529

California
Phone: 562-941-7610
Fax: 562-941-7810

Aftermarket Value Services

Dresser - Masoneilan, a leading manufacturer of automated process control solutions, offers world-class global aftermarket services. Consistent and high quality services executed through a network of fully authorized and certified third party service centers, as well as company owned facilities include: Valve Repair, Technical Training, Field Support, Spare Parts Supply, Complete Equipment Replacement and Comprehensive Diagnostics.

About Dresser, Inc.

Dresser, Inc. is a leader in providing highly engineered infrastructure products for the global energy industry. The company has leading positions in a broad portfolio of products including valves, actuators, meters, switches, regulators, piping products, natural gas-fueled engines, retail fuel dispensers and associated retail point of sale systems and air and gas handling equipment.

Leading brand names within the Dresser portfolio include Dresser Wayne® retail fueling systems, Waukesha® natural gas-fired engines, Masoneilan® control valves, Mooney® regulators, Consolidated® pressure relief valves, and Roots® blowers and rotary gas meters. It has manufacturing and customer service facilities located strategically worldwide and a sales presence in more than 100 countries. The company's website can be accessed at www.dresser.com.

Dresser Masoneilan

85 Bodwell Street
Avon, MA 02322-1190
Tele: 508-586-4600 / Fax: 508-941-5497
Email: sales@masoneilan.com

Dresser Masoneilan

With its breadth of products, unequalled global presence and advanced process control expertise, Dresser Masoneilan is uniquely positioned to be the leading provider of flexible, best fit control valve solutions.

Supported by an integrated network of sales offices, Dresser Masoneilan provides the widest range of valve solutions and services for virtually every process control application.

